

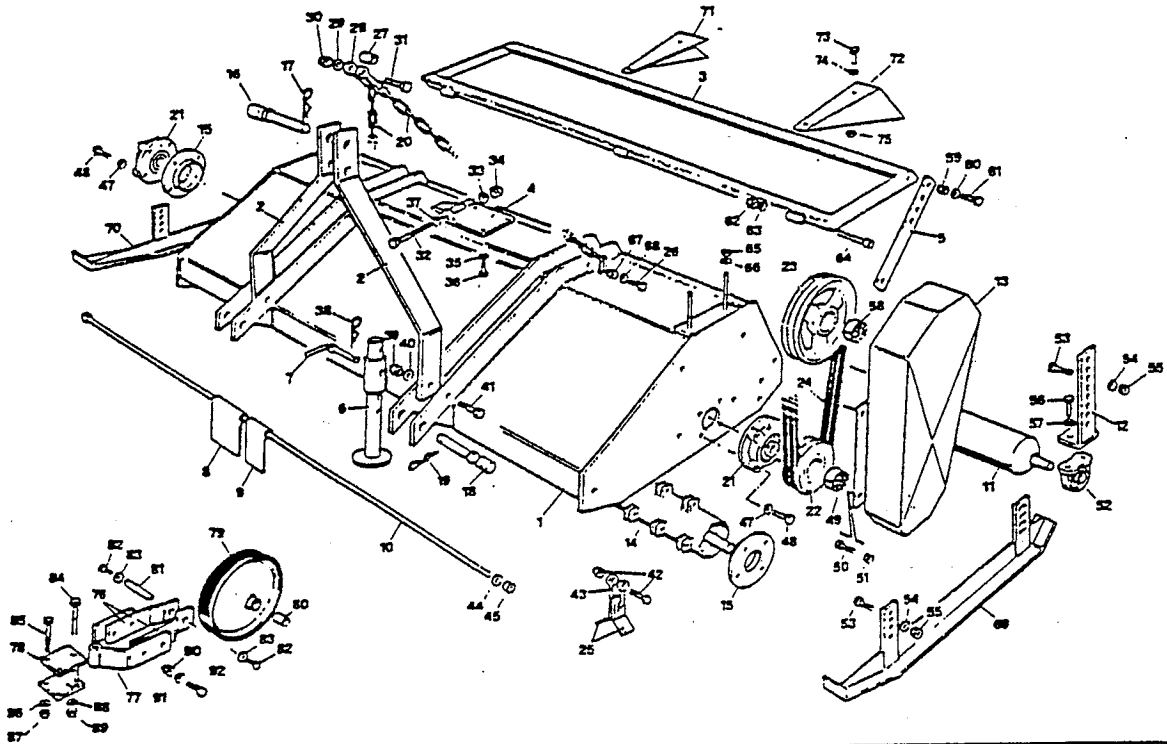

FM

FRAME-CHASSIS-TELAIO-RAHMEN-BASTIDOR
 ROTOR-ROTOR-ROTORE -ROTOR-ROTOR

H.4.1.0



REF	CODE	QTY	ENGLISH	FRANÇAIS	ITALIANO	DEUTSCH	ESPAÑOL	NOTE
FM								H.4.1.0
1	900.240.100	1	FRAME	CHASSIS	TELAIO	RAHMEN	SOPORTE	120
1	900.240.101	1	FRAME	CHASSIS	TELAIO	RAHMEN	SOPORTE	150
1	900.240.102	1	FRAME	CHASSIS	TELAIO	RAHMEN	SOPORTE	180
1	900.240.103	1	FRAME	CHASSIS	TELAIO	RAHMEN	SOPORTE	210
2	900.240.099	2	TIE ROD	TIRANT	TIRANTE	ZUGSTANGE	TIRANTE	120-150
2	900.240.190	2	TIE ROD	TIRANT	TIRANTE	ZUGSTANGE	TIRANTE	180-210
3	900.240.104	1	SHIELD	CAPOT	COFANO	HAUBE	CARCASA	120
3	900.240.105	1	SHIELD	CAPOT	COFANO	HAUBE	CARCASA	150
3	900.240.106	1	SHIELD	CAPOT	COFANO	HAUBE	CARCASA	180
3	900.240.107	1	SHIELD	CAPOT	COFANO	HAUBE	CARCASA	210
4	900.240.108	1	SUPPORT	SUPPORT	SUPPORTO	STUETZE	SOPORTE	120-150
4	900.240.109	1	SUPPORT	SUPPORT	SUPPORTO	STUETZE	SOPORTE	180-210
5	900.240.110	2	ARM	BRAS	BRACCIO	ARM	BRAZO	
6	900.238.001	1	STAND	SUPPORT	SOSTEGNO	STUETZE	SOPORTE	
7	900.207.008	1	PIN	CHEVILLE	SPINA	DORN	CLAVIJA	
8	900.238.064	-	FLAP	AILETTE	ALETTA	SCHUTZLAMELLE	ALETA	
9	900.238.063	-	FLAP	AILETTE	ALETTA	SCHUTZLAMELLE	ALETA	
10	900.240.112	1	ROD	TIGE	ASTA	ARM	VARILLA	120
10	900.240.113	1	ROD	TIGE	ASTA	ARM	VARILLA	150
10	900.240.114	1	ROD	TIGE	ASTA	ARM	VARILLA	180
10	900.240.115	1	ROD	TIGE	ASTA	ARM	VARILLA	210
11	900.240.116	1	ROLLER	ROULEAU	RULLO	WALZE	RODILLO	120
11	900.240.117	1	ROLLER	ROULEAU	RULLO	WALZE	RODILLO	150
11	900.240.118	1	ROLLER	ROULEAU	RULLO	WALZE	RODILLO	180
11	900.240.119	1	ROLLER	ROULEAU	RULLO	WALZE	RODILLO	210
12	900.240.120	2	FLASK	MOULE	STAFFA	FORMKASTEN	PLETINA	
13	900.240.121	1	COVER	CARTER	CARTER	CARTER	CARTER	120-150
13	900.240.122	1	COVER	CARTER	CARTER	CARTER	CARTER	180-210
14	900.240.123	1	ROTOR	ROTOR	ROTORE	ROTOR	ROTOR	120
14	900.240.124	1	ROTOR	ROTOR	ROTORE	ROTOR	ROTOR	150
14	900.240.125	1	ROTOR	ROTOR	ROTORE	ROTOR	ROTOR	180
14	900.240.126	1	ROTOR	ROTOR	ROTORE	ROTOR	ROTOR	210
15	900.240.127	2	FLANGE	FLASQUE	FLANGIA	FLANSCH	BRIDA	120-150
15	900.240.128	2	FLANGE	FLASQUE	FLANGIA	FLANSCH	BRIDA	180-210
16	900.240.053	1	PIN	TOURILLON	PERNO	STIFT	PERNO	
17	900.108.017	1	SPLIT PIN	GOUPILLE	COPIGLIA	ARRETIERUNG	PASADOR	
18	900.116.044	2	PIN	TOURILLON	PERNO	STIFT	PERNO	
19	900.108.017	2	SPLIT PIN	GOUPILLE	COPIGLIA	ARRETIERUNG	PASADOR	
20	900.240.129	2	CHAIN	CHAIN	CATENA	KETTE	CADENA	120-150
20	900.240.130	2	CHAIN	CHAIN	CATENA	KETTE	CADENA	180-210
21	900.100.093	2	SUPPORT	SUPPORT	SUPPORTO	STUETZE	SOPORTE	120-150
21	900.100.088	2	SUPPORT	SUPPORT	SUPPORTO	STUETZE	SOPORTE	180-210
22	900.240.081	1	PULLEY	POULIE	PULEGGIA	REIMENSCHLEIBE	POLEA	120-150
22	900.238.087	1	PULLEY	POULIE	PULEGGIA	REIMENSCHLEIBE	POLEA	180-210
23	900.240.080	1	PULLEY	POULIE	PULEGGIA	REIMENSCHLEIBE	POLEA	120-150
23	900.238.083	1	PULLEY	POULIE	PULEGGIA	REIMENSCHLEIBE	POLEA	180-210

REF	CODE	QTY	ENGLISH	FRANÇAIS	ITALIANO	DEUTSCH	ESPAÑOL	NOTE
FM								H.4.1.0
24	900.240.079	2	BELT	COURROIE	CINGHIA	RIEMEN	CINTA	120-150
24	900.241.392	3	BELT	COURROIE	CINGHIA	RIEMEN	CINTA	180-210
25	900.240.060	--	KNIFE	COUTEAU	COLTELLO	MESSER	CUCHILLA	
26	900.102.065	2	BOLT	VIS	VITE	SCHRAUBE	TORNILLO	
27	900.241.173	1	SPACER	ENTRETOISE	DISTANZIALE	ABSTANDSRING	DISTANCIADOR	
28	900.241.174	1	U-BOLT	MANILLE	CAVALLOTTO	U-BOLZEN	SOPORTE	
29	900.104.046	1	WASHER	RONDELLE	RONDELLA	ZWISCHENSCHIEBE	ARANDELA	
30	900.103.019	1	NUT	ECROU	DADO	MUTTER	TUERCA	
31	900.102.251	1	BOLT	VIS	VITE	SCHRAUBE	TORNILLO	
32	900.102.070	1	BOLT	VIS	VITE	SCHRAUBE	TORNILLO	120-150
32	900.102.200	1	BOLT	VIS	VITE	SCHRAUBE	TORNILLO	180-210
34	900.103.019	1	NUT	ECROU	DADO	MUTTER	TUERCA	120-150
34	900.103.021	1	NUT	ECROU	DADO	MUTTER	TUERCA	180-210
36	900.102.019	4	BOLT	VIS	VITE	SCHRAUBE	TORNILLO	
38	900.108.005	1	SPLIT PIN	GOUPILLE	COPIGLIA	ARRETIERUNG	PASADOR	
39	900.103.021	2	NUT	ECROU	DADO	MUTTER	TUERCA	
41	900.102.096	2	BOLT	VIS	VITE	SCHRAUBE	TORNILLO	
42	900.102.252	--	BOLT	VIS	VITE	SCHRAUBE	TORNILLO	
43	900.240.061	--	U-BOLT	MANILLE	CAVALLOTTO	U-BOLZEN	SOPORTE	
44	900.104.046	2	WASHER	RONDELLE	RONDELLA	ZWISCHENSCHIEBE	ARANDELA	
45	900.103.019	2	NUT	ECROU	DADO	MUTTER	TUERCA	
47	900.104.054	4	WASHER	RONDELLE	RONDELLA	ZWISCHENSCHIEBE	ARANDELA	
48	900.102.021	8	BOLT	VIS	VITE	SCHRAUBE	TORNILLO	
49	900.240.131	1	CLAMPING	BLOCAGE	CALETTATORE	KLEMMHUELSE	ENSAMBLADOR	120-150
49	900.238.091	1	CLAMPING	BLOCAGE	CALETTATORE	KLEMMHUELSE	ENSAMBLADOR	180-210
50	900.102.124	4	BOLT	VIS	VITE	SCHRAUBE	TORNILLO	
51	900.103.020	4	NUT	ECROU	DADO	MUTTER	TUERCA	
52	900.100.082	2	SUPPORT	SUPPORT	SUPPORTO	STUETZE	SOPORTE	120-150
52	900.100.030	2	SUPPORT	SUPPORT	SUPPORTO	STUETZE	SOPORTE	180-210
53	900.102.098	4	BOLT	VIS	VITE	SCHRAUBE	TORNILLO	
54	900.104.046	4	WASHER	RONDELLE	RONDELLA	ZWISCHENSCHIEBE	ARANDELA	
55	900.103.019	4	NUT	ECROU	DADO	MUTTER	TUERCA	
56	900.102.100	4	BOLT	VIS	VITE	SCHRAUBE	TORNILLO	120-150
56	900.102.096	4	BOLT	VIS	VITE	SCHRAUBE	TORNILLO	180-210
57	900.103.019	4	NUT	ECROU	DADO	MUTTER	TUERCA	120-150
57	900.103.021	4	NUT	ECROU	DADO	MUTTER	TUERCA	180-210
58	900.240.131	1	CLAMPING	BLOCAGE	CALETTATORE	KLEMMHUELSE	ENSAMBLADOR	120-150
58	900.238.091	1	CLAMPING	BLOCAGE	CALETTATORE	KLEMMHUELSE	ENSAMBLADOR	180-210
59	900.103.018	4	NUT	ECROU	DADO	MUTTER	TUERCA	
60	900.104.045	4	WASHER	RONDELLE	RONDELLA	ZWISCHENSCHIEBE	ARANDELA	
61	900.102.100	4	BOLT	VIS	VITE	SCHRAUBE	TORNILLO	
62	900.103.018	3	NUT	ECROU	DADO	MUTTER	TUERCA	
64	900.102.204	3	BOLT	VIS	VITE	SCHRAUBE	TORNILLO	
65	900.103.035	4	NUT	ECROU	DADO	MUTTER	TUERCA	
66	900.104.046	2	WASHER	RONDELLE	RONDELLA	ZWISCHENSCHIEBE	ARANDELA	
67	900.103.019	2	NUT	ECROU	DADO	MUTTER	TUERCA	
68	900.104.047	2	WASHER	RONDELLE	RONDELLA	ZWISCHENSCHIEBE	ARANDELA	
69	900.240.135	1	SKID	PATIN	SLITTA	KUFE	CORREDERA	
70	900.240.134	1	SKID	PATIN	SLITTA	KUFE	CORREDERA	
71	900.240.138	--	AILERON	AILERON	ALETTONE	FLUEGEL	ALERON	
72	900.240.139	--	AILERON	AILERON	ALETTONE	FLUEGEL	ALERON	
73	900.102.101	--	BOLT	VIS	VITE	SCHRAUBE	TORNILLO	
74	900.104.045	--	WASHER	RONDELLE	RONDELLA	ZWISCHENSCHIEBE	ARANDELA	
75	900.103.018	--	NUT	ECROU	DADO	MUTTER	TUERCA	
76	900.240.136	4	ARM	BRAS	BRACCIO	ARM	BRAZO	
77	900.240.137	2	FORK	FOURCHETTE	FORCELLA	GABEL	HORQUILLA	
78	900.240.140	2	SUPPORT	SUPPORT	SUPPORTO	STUETZE	SOPORTE	120-150
78	900.240.141	2	SUPPORT	SUPPORT	SUPPORTO	STUETZE	SOPORTE	180-210
79	900.240.142	2	WHEEL	ROUE	RUOTA	RAD	RUEDA	
80	900.240.143	2	BUSH	COQUILLE	BOCCOLA	BUCHSE	CASQUILLO	
81	900.240.144	2	PIN	TOURILLON	PERNO	STIFT	PERNO	
82	900.102.098	4	BOLT	VIS	VITE	SCHRAUBE	TORNILLO	
83	900.104.046	4	WASHER	RONDELLE	RONDELLA	ZWISCHENSCHIEBE	ARANDELA	
84	900.102.151	2	BOLT	VIS	VITE	SCHRAUBE	TORNILLO	
85	900.102.206	4	BOLT	VIS	VITE	SCHRAUBE	TORNILLO	
86	900.104.046	4	WASHER	RONDELLE	RONDELLA	ZWISCHENSCHIEBE	ARANDELA	
87	900.103.019	4	NUT	ECROU	DADO	MUTTER	TUERCA	
88	900.104.048	2	WASHER	RONDELLE	RONDELLA	ZWISCHENSCHIEBE	ARANDELA	
89	900.103.106	2	NUT	ECROU	DADO	MUTTER	TUERCA	
90	900.103.019	8	NUT	ECROU	DADO	MUTTER	TUERCA	
91	900.104.046	8	WASHER	RONDELLE	RONDELLA	ZWISCHENSCHIEBE	ARANDELA	
92	900.102.102	8	BOLT	VIS	VITE	SCHRAUBE	TORNILLO	
93	900.102.102	4	BOLT	VIS	VITE	SCHRAUBE	TORNILLO	
94	900.103.019	--	NUT	ECROU	DADO	MUTTER	TUERCA	
95	900.104.045	4	WASHER	RONDELLE	RONDELLA	ZWISCHENSCHIEBE	ARANDELA	120-150
95	900.104.044	4	WASHER	RONDELLE	RONDELLA	ZWISCHENSCHIEBE	ARANDELA	180-210



FM 120-150 < 39590
GEARBOX-BOITE DE VITESSE-GRUPPO-GETRIEBE-REDUCTOR H.4.2.0

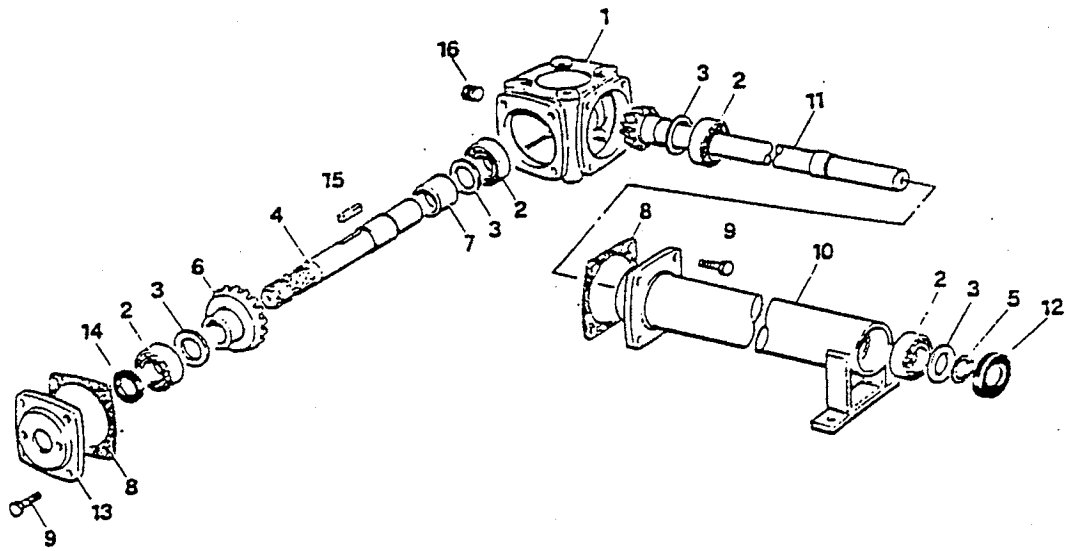

REF	CODE	QTY	ENGLISH	FRANÇAIS	ITALIANO	DEUTSCH	ESPAÑOL	NOTE
FM (120-150) > 39590								H.4.2.0
1	900.240.092	1	CASE	BOITE	SCATOLA	KISTE	CAJA	
2	900.100.008	4	BEARING	ROULEMENT	CUSCINETTO	KUGELLAGER	COJINETE	
3	900.107.056	4	SHIM	EPAISSEUR	SPESSORE REG.	STAERKE	ESPESOR REG.	
4	900.240.093	1	SHAFT	ARBRE	ALBERO	WELLE	EJE	
5	900.106.013	1	CIRCLIP	SERFLEX	SEEGER	SEEGER	SEEGER	
6	900.240.094	1	CROWN	COURONNE	CORONA	TELLERRAD	CORONA	
7	900.240.096	1	SPACER	ENTRETOISE	DISTANZIALE	ABSTANDSRING	DISTANCIADOR	
8	900.139.098	2	GASKET	JOINT	GUARNIZIONE	DICHTUNG	JUNTA	
9	900.102.018	8	BOLT	VIS	VITE	SCHRAUBE	TORNILLO	
10	900.240.097	1	EXSTENSION	PROLONGE	PROLUNGA	VERLAENGERUNG	PROLONGACION	
11	900.240.095	1	PINION	PIGNON	PIGNONE	RITZEL	PINON	
12	900.101.009	1	OIL SEAL	PARE-HUILE	PARAOLIO	SIMMERRING	PARA-ACEITE	
13	900.240.098	1	LID	COUVERCLE	COPERCHIO	DECKEL	TAPA	
14	900.101.054	1	OIL SEAL	PARE-HUILE	PARAOLIO	SIMMERRING	PARA-ACEITE	
15	900.105.002	1	KEY	CLAVETTE	CHIAVETTA	KEIL	CHAVETA	
16	900.102.109	1	PLUG	BOUCHON	TAPPO	ZAPFEN	TAPON	



FM 180-210 < 39590
GEARBOX-BOITE DE VITESSE-GRUPPO-GETRIEBE-REDUCTOR H.4.2.3

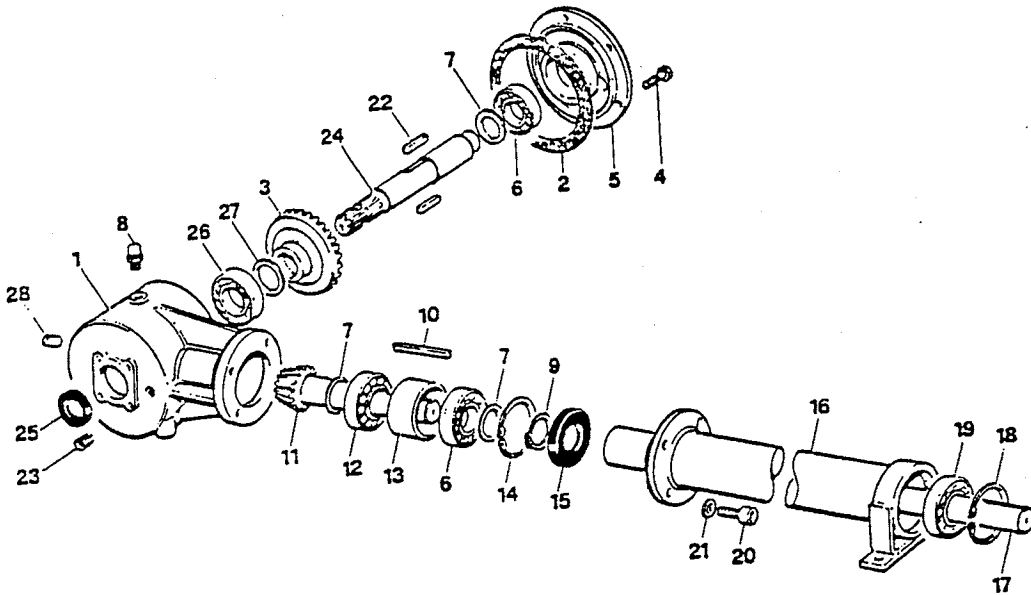

REF	CODE	QTY	ENGLISH	FRANÇAIS	ITALIANO	DEUTSCH	ESPAÑOL	NOTE
	FM (180-210) < 39590							H.4.2.3
1	900.240.074	1	CASE	BOITE	SCATOLA	KISTE	CAJA	
2	900.139.097	1	GASKET	JOINT	GUARNIZIONE	DICHTUNG	JUNTA	
3	900.240.072	1	CROWN	COURONNE	CORONA	TELLERRAD	CORONA	
4	900.102.003	6	BOLT	VIS	VITE	SCHRAUBE	TORNILLO	
5	900.240.082	1	LID	COUVERCLE	COPERCHIO	DECKEL	TAPA	
6	900.100.008	2	BEARING	ROULEMENT	CUSCINETTO	KUGELLAGER	COJINETE	
7	900.107.048	3	SHIM	EPAISSEUR	SPESSORE REG.	STAERKE	ESPESOR REG.	
8	900.102.110	1	PLUG	BOUCHON	TAPPO	ZAPFEN	TAPON	
9	900.106.013	1	CIRCLIP	SERFLEX	SEEGER	SEEGER	SEEGER	
10	900.105.036	1	KEY	CLAVETTE	CHIAVETTA	KEIL	CHAVETA	
11	900.240.071	1	PINION	PIGNON	PIGNONE	RITZEL	PINON	
12	900.100.020	1	BEARING	ROULEMENT	CUSCINETTO	KUGELLAGER	COJINETE	
13	900.240.083	1	SPACER	ENTRETOISE	DISTANZIALE	ABSTANDSRING	DISTANCIADOR	
14	900.106.012	1	CIRCLIP	SERFLEX	SEEGER	SEEGER	SEEGER	
15	900.101.009	1	OIL SEAL	PARE-HUILE	PARAOILIO	SIMMERRING	PARA-ACEITE	
16	900.240.088	1	EXSTENSION	PROLONGE	PROLUNGA	VERLAENGERUNG	PROLONGACION	180
16	900.240.089	1	EXSTENSION	PROLONGE	PROLUNGA	VERLAENGERUNG	PROLONGACION	210
17	900.240.090	1	SHAFT	ARBRE	ALBERO	WELLE	EJE	180
17	900.240.091	1	SHAFT	ARBRE	ALBERO	WELLE	EJE	210
18	900.106.005	1	CIRCLIP	SERFLEX	SEEGER	SEEGER	SEEGER	
19	900.100.052	1	BEARING	ROULEMENT	CUSCINETTO	KUGELLAGER	COJINETE	
20	900.102.202	4	BOLT	VIS	VITE	SCHRAUBE	TORNILLO	
21	900.104.034	4	WASHER	RONDELLE	RONDELLA	ZWISCHENSCHIEBE	ARANDELA	
22	900.105.002	2	KEY	CLAVETTE	CHIAVETTA	KEIL	CHAVETA	
23	900.102.079	1	PLUG	BOUCHON	TAPPO	ZAPFEN	TAPON	
24	900.240.073	1	SHAFT	ARBRE	ALBERO	WELLE	EJE	
25	900.101.024	1	OIL SEAL	PARE-HUILE	PARAOILIO	SIMMERRING	PARA-ACEITE	
26	900.100.033	1	BEARING	ROULEMENT	CUSCINETTO	KUGELLAGER	COJINETE	
27	900.107.050	1	SHIM	EPAISSEUR	SPESSORE REG.	STAERKE	ESPESOR REG.	
28	900.102.109	1	PLUG	BOUCHON	TAPPO	ZAPFEN	TAPON	



FM 120-150 > 56500
GEARBOX-BOITE DE VITESSE-GRUPPO-GETRIEBE-REDUCTOR H.4.2.2

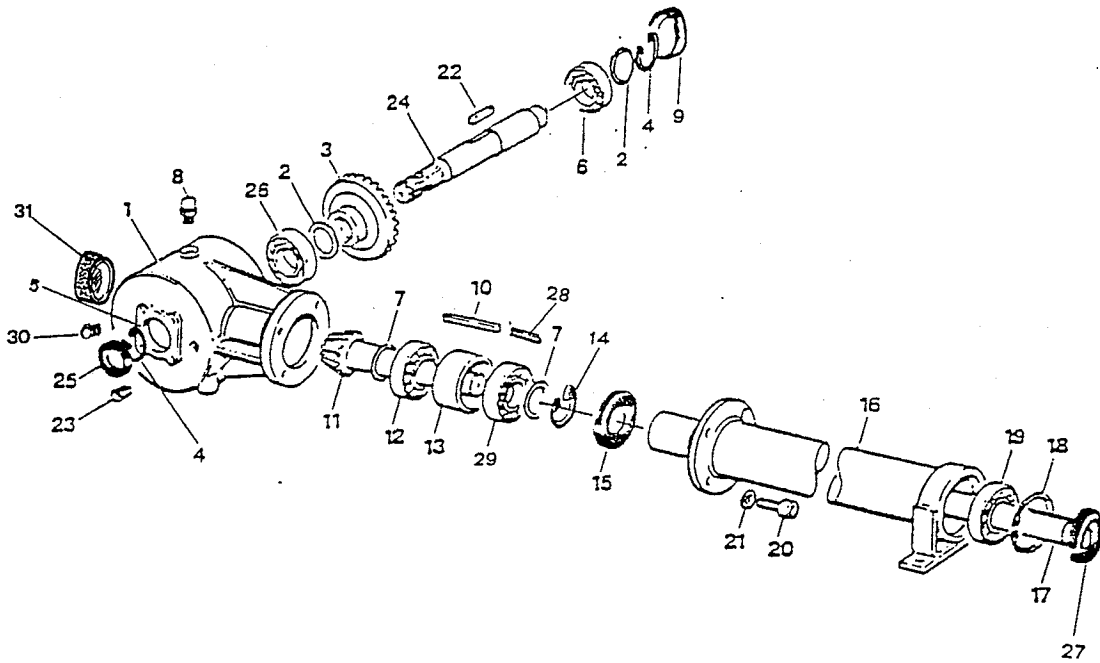

REF	CODE	QTY	ENGLISH	FRANÇAIS	ITALIANO	DEUTSCH	ESPAÑOL	NOTE
	FM (120-150) > 56500							H.4.2.2
1	900.240.261	1	CASE	BOITE	SCATOLA	KISTE	CAJA	
2	900.107.066	2	SHIM	EPAISSEUR	SPESSORE REG.	STAERKE	ESPEJOR REG.	
3	900.240.262	1	CROWN	COURONNE	CORONA	TELLERRAD	CORONA	
4	900.106.011	2	CIRCLIP	SERFLEX	SEEGER	SEEGER	SEEGER	
5	900.240.263	1	LID	COUVERCLE	COPERCHIO	DECKEL	TAPA	
6	900.100.033	2	BEARING	ROULEMENT	CUSCINETTO	KUGELLAGER	COJINETE	
7	900.107.048	2	SHIM	EPAISSEUR	SPESSORE REG.	STAERKE	ESPEJOR REG.	
8	900.102.079	1	PLUG	BOUCHON	TAPPO	ZAPFEN	TAPON	
9	900.240.253	2	LID	COUVERCLE	COPERCHIO	DECKEL	TAPA	
10	900.105.004	1	KEY	CLAVETTE	CHIAVETTA	KEIL	CHAVETA	
11	900.240.264	1	PINION	PIGNONE	PIGNONE	RITZEL	PINON	
12	900.100.020	1	BEARING	ROULEMENT	CUSCINETTO	KUGELLAGER	COJINETE	
13	900.240.265	1	BUSH	COQUILLE	BOCCOLA	BUCHSE	CASQUILLO	
14	900.106.013	1	CIRCLIP	SERFLEX	SEEGER	SEEGER	SEEGER	
15	900.101.009.A	1	OIL SEAL	PARE-HUILE	PARAOLIO	SIMMERRING	PARA-ACEITE	
16	900.240.268	1	EXSTENSION	PROLONGE	PROLUNGA	VERLAENGERUNG	PROLONGACION	120
16	900.240.266	1	EXSTENSION	PROLONGE	PROLUNGA	VERLAENGERUNG	PROLONGACION	150
17	900.240.007	1	SHAFT	ARBRE	ALBERO	WELLE	EJE	120
17	900.240.267	1	SHAFT	ARBRE	ALBERO	WELLE	EJE	150
18	900.106.012	1	CIRCLIP	SERFLEX	SEEGER	SEEGER	SEEGER	
19	900.100.008.A	1	BEARING	ROULEMENT	CUSCINETTO	KUGELLAGER	COJINETE	
20	900.102.005	4	BOLT	VIS	VITE	SCHRAUBE	TORNILLO	
22	900.105.029	1	KEY	CLAVETTE	CHIAVETTA	KEIL	CHAVETA	
23	900.102.290	2	PLUG	BOUCHON	TAPPO	ZAPFEN	TAPON	
24	900.240.260	1	SHAFT	ARBRE	ALBERO	WELLE	EJE	
25	900.101.066	1	OIL SEAL	PARE-HUILE	PARAOLIO	SIMMERRING	PARA-ACEITE	
26	900.106.026	1	CIRCLIP	SERFLEX	SEEGER	SEEGER	SEEGER	
27	900.101.009	1	OIL SEAL	PARE-HUILE	PARAOLIO	SIMMERRING	PARA-ACEITE	
28	900.105.003	1	KEY	CLAVETTE	CHIAVETTA	KEIL	CHAVETA	
29	900.100.008	1	BEARING	ROULEMENT	CUSCINETTO	KUGELLAGER	COJINETE	
30	900.102.280	1	PLUG	BOUCHON	TAPPO	ZAPFEN	TAPON	
31	900.102.011	9	BOLT	VIS	VITE	SCHRAUBE	TORNILLO	
32	900.117.070	1	PROT. HOLDER	DISQUE	FONDELLO	ZWSCHUTZHALTER	DISCO	
33	900.117.072	1	GUARD	PROTECTION	PROTEZIONE	SCHUTZ	PROTECCION	
34	900.102.256	7	BOLT	VIS	VITE	SCHRAUBE	TORNILLO	
35	900.104.054	4	WASHER	RONDELLE	RONDELLA	ZWISCHENSCHIEBE	ARANDELA	



FM 120-150 > 39590 < 56499
GEARBOX-BOITE DE VITESSE-GRUPPO-GETRIEBE-REDUCTOR H.4.2.1

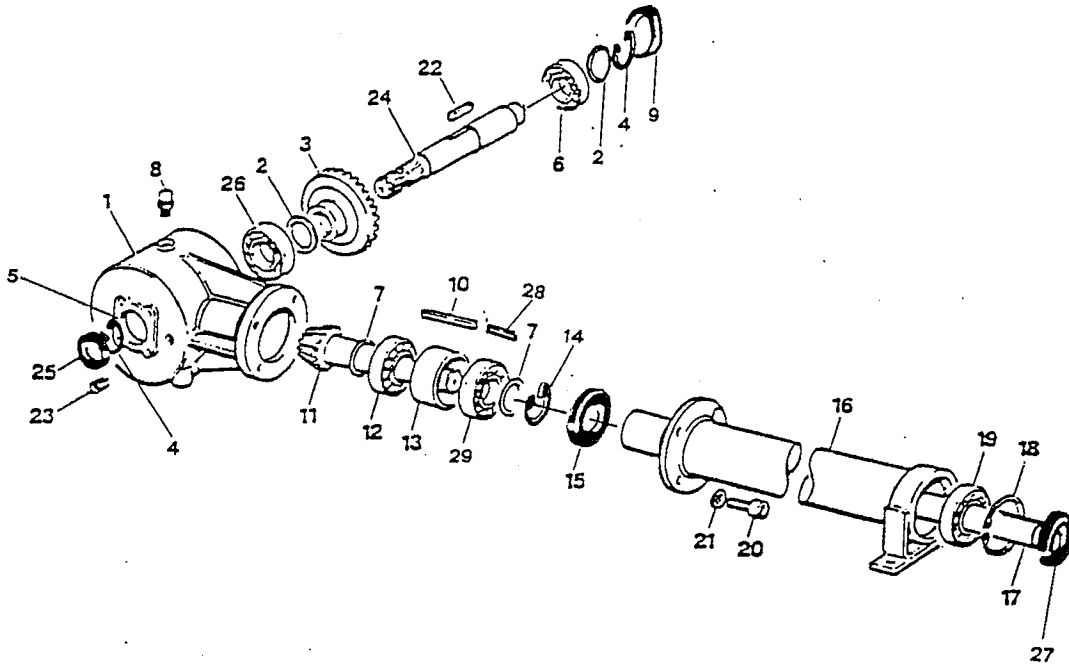

REF	CODE	QTY	ENGLISH	FRANCAIS	ITALIANO	DEUTSCH	ESPAÑOL	NOTE
FM (120-150) < 56499								H.4.2.1
1	900.240.261	1	CASE	BOITE	SCATOLA	KISTE	CAJA	
2	900.107.066	2	SHIM	EPAISSEUR	SPESSORE REG.	STAERKE	ESPESOR REG.	
3	900.240.262	1	CROWN	COURONNE	CORONA	TELLERRAD	CORONA	
4	900.106.011	2	CIRCLIP	SERFLEX	SEEGER	SEEGER	SEEGER	
5	900.240.263	1	LID	COUVERCLE	COPERCHIO	DECKEL	TAPA	
6	900.100.033	1	BEARING	ROULEMENT	CUSCINETTO	KUGELLAGER	COJINETE	
7	900.107.043	2	SHIM	EPAISSEUR	SPESSORE REG.	STAERKE	ESPESOR REG.	
8	900.102.110	1	PLUG	BOUCHON	TAPPO	ZAPFEN	TAPON	
9	900.240.253	1	LID	COUVERCLE	COPERCHIO	DECKEL	TAPA	
10	900.105.004	1	KEY	CLAVETTE	CHIAVETTA	KEIL	CHAVETA	
11	900.240.264	1	PINION	PIGNON	PIGNONE	RITZEL	PINON	
12	900.100.020	1	BEARING	ROULEMENT	CUSCINETTO	KUGELLAGER	COJINETE	
13	900.240.265	1	BUSH	COQUILLE	BOCCOLA	BUCHSE	CASQUILLO	
14	900.106.013	1	CIRCLIP	SERFLEX	SEEGER	SEEGER	SEEGER	
15	900.101.009	1	OIL SEAL	PARE-HUILE	PARAOLIO	SIMMERRING	PARA-ACEITE	
16	900.240.266	1	EXTENSION	PROLONGE	PROLUNGA	VERLAENGERUNG	PROLONGACION	
17	900.240.267	1	SHAFT	ARBRE	ALBERO	WELLE	EJE	
18	900.106.012	1	CIRCLIP	SERFLEX	SEEGER	SEEGER	SEEGER	
19	900.100.008	1	BEARING	ROULEMENT	CUSCINETTO	KUGELLAGER	COJINETE	
20	900.102.005	4	BOLT	VIS	VITE	SCHRAUBE	TORNILLO	
21	900.104.035	4	WASHER	RONDELLE	RONDELLA	ZWISCHENSCHIEBE	ARANDELA	
22	900.105.029	1	KEY	CLAVETTE	CHIAVETTA	KEIL	CHAVETA	
23	900.102.236	4	PLUG	BOUCHON	TAPPO	ZAPFEN	TAPON	
24	900.240.260	1	SHAFT	ARBRE	ALBERO	WELLE	EJE	
25	900.101.066	1	OIL SEAL	PARE-HUILE	PARAOLIO	SIMMERRING	PARA-ACEITE	
26	900.100.033	1	BEARING	ROULEMENT	CUSCINETTO	KUGELLAGER	COJINETE	
27	900.101.009	1	OIL SEAL	PARE-HUILE	PARAOLIO	SIMMERRING	PARA-ACEITE	
28	900.105.003	1	KEY	CLAVETTE	CHIAVETTA	KEIL	CHAVETA	
29	900.100.008	1	BEARING	ROULEMENT	CUSCINETTO	KUGELLAGER	COJINETE	



FM 180-210 > 39591
GEARBOX-BOITE DE VITESSE-GRUPPO-GETRIEBE-REDUCTOR H.4.2.4

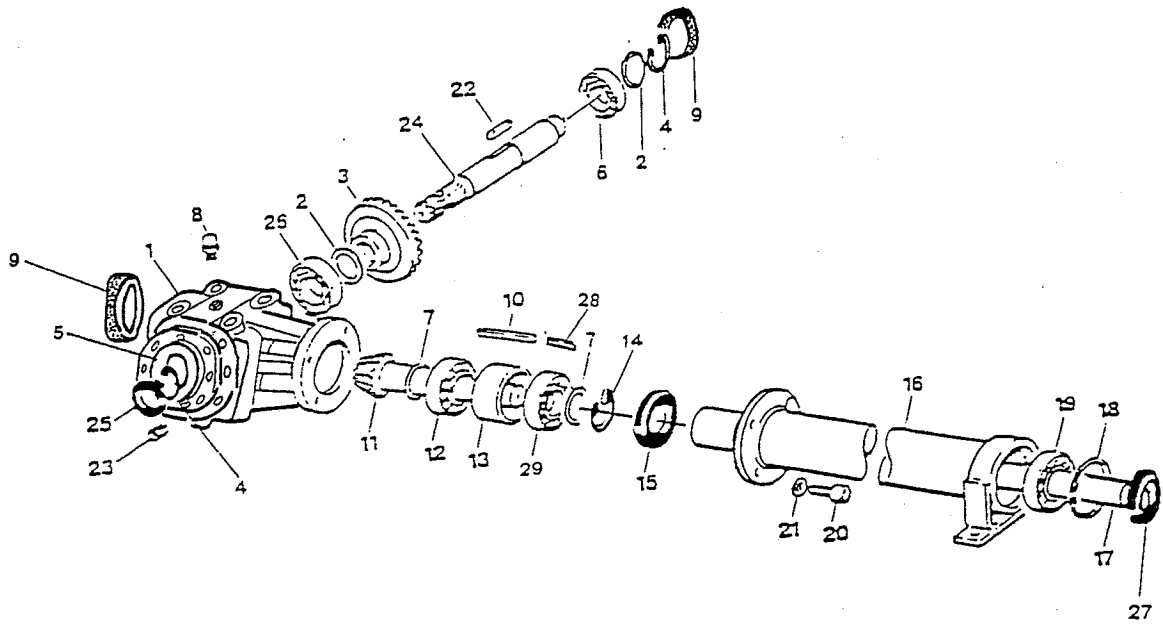

REF	CODE	QTY	ENGLISH	FRANÇAIS	ITALIANO	DEUTSCH	ESPAÑOL	NOTE
	FM (180-210) > 39591							H.4.2.4
1	900.240.250	1	CASE	BOITE	SCATOLA	KISTE	CAJA	
2	900.107.066	2	SHIM	EPAISSEUR	SPESSORE REG.	STAERKE	ESPESOR REG.	
3	900.240.251	1	CROWN	COURONNE	CORONA	TELLERRAD	CORONA	
4	900.106.011	2	CIRCLIP	SERFLEX	SEEGER	SEEGER	SEEGER	
5	900.240.252	1	LID	COUVERCLE	COPERCHIO	DECKEL	TAPA	
6	900.100.033	2	BEARING	ROULEMENT	CUSCINETTO	KUGELLAGER	COJINETE	
7	900.107.048	2	SHIM	EPAISSEUR	SPESSORE REG.	STAERKE	ESPESOR REG.	
8	900.102.079	1	PLUG	BOUCHON	TAPPO	ZAPFEN	TAPON	
9	900.240.253	2	LID	COUVERCLE	COPERCHIO	DECKEL	TAPA	
10	900.105.044	1	KEY	CLAVETTE	CHIAVETTA	KEIL	CHAVETA	
11	900.240.254	1	PINION	PIGNON	PIGNONE	RITZEL	PINON	
12	900.100.037	1	BEARING	ROULEMENT	CUSCINETTO	KUGELLAGER	COJINETE	
13	900.240.255	1	BUSH	COQUILLE	BOCCOLA	BUCHSE	CASQUILLO	
14	900.106.013	1	CIRCLIP	SERFLEX	SEEGER	SEEGER	SEEGER	
15	900.101.009.A	1	OIL SEAL	PARE-HUILE	PARAOLIO	SIMMERRING	PARA-ACEITE	
16	900.240.256	1	EXSTENSION	PROLONGE	PROLUNGA	VERLAENGERUNG	PROLONGACION	180
16	900.240.257	1	EXSTENSION	PROLONGE	PROLUNGA	VERLAENGERUNG	PROLONGACION	210
17	900.240.258	1	SHAFT	ARBRE	ALBERO	WELLE	EJE	180
17	900.240.259	1	SHAFT	ARBRE	ALBERO	WELLE	EJE	210
18	900.106.005	1	CIRCLIP	SERFLEX	SEEGER	SEEGER	SEEGER	
19	900.100.016	1	BEARING	ROULEMENT	CUSCINETTO	KUGELLAGER	COJINETE	
20	900.102.206	4	BOLT	VIS	VITE	SCHRAUBE	TORNILLO	
21	900.106.026	1	SERFLEX	SEEGER	SEEGER	SEEGER	SEEGER	
22	900.105.029	1	KEY	CLAVETTE	CHIAVETTA	KEIL	CHAVETA	
23	900.102.280	3	PLUG	BOUCHON	TAPPO	ZAPFEN	TAPON	
24	900.240.260	1	SHAFT	ARBRE	ALBERO	WELLE	EJE	
25	900.101.066	1	OIL SEAL	PARE-HUILE	PARAOLIO	SIMMERRING	PARA-ACEITE	
26	900.102.011	8	BOLT	VIS	VITE	SCHRAUBE	TORNILLO	
27	900.101.076	1	OIL SEAL	PARE-HUILE	PARAOLIO	SIMMERRING	PARA-ACEITE	
28	900.105.005	1	KEY	CLAVETTE	CHIAVETTA	KEIL	CHAVETA	
29	900.100.008	1	BEARING	ROULEMENT	CUSCINETTO	KUGELLAGER	COJINETE	
30	900.117.070	1	PROT. HOLDER	DISQUE	FONDELLO	ZWSCHUTZHALTER	DISCO	
31	900.117.072	1	GUARD	PROTECTION	PROTEZIONE	SCHUTZ	PROTECCION	
32	900.102.256	7	BOLT	VIS	VITE	SCHRAUBE	TORNILLO	
33	900.104.054	4	WASHER	RONDELLE	RONDELLA	ZWISCHENSCHLEIBE	ARANDELA	